

PLAN

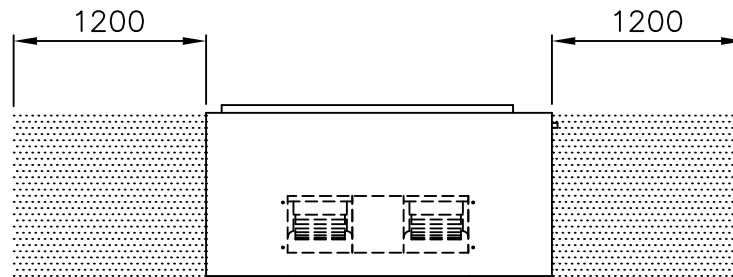

CLEARANCE DETAIL  
NTS

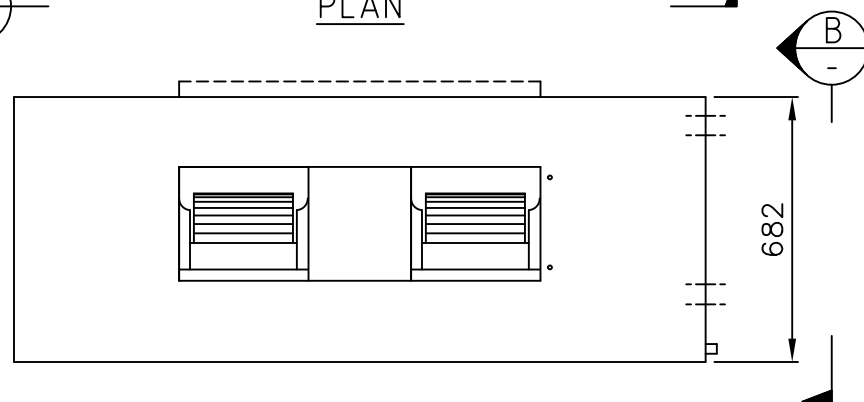

VIEW A

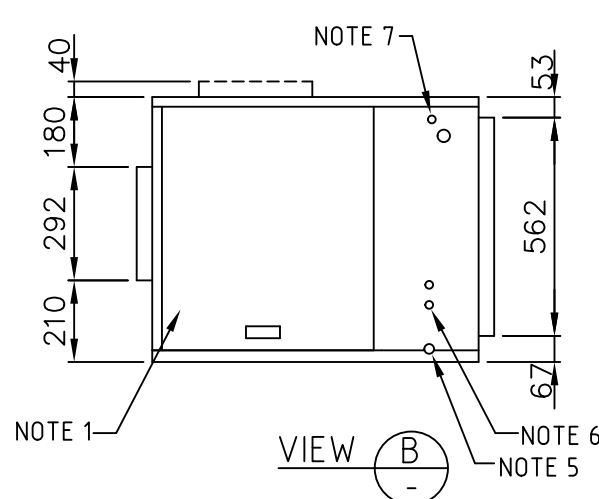

VIEW B

- NOTE:**
1. CABINET SERVICE ACCESS.
  2. TRANSPORTATION FEET (REMOVAL IS OPTIONAL).
  3. AV MOUNTING LOCATIONS (FEET MUST BE REMOVED).
  4. RECOMMENDED LIFTING POINTS (SPREADER BARS MUST BE USED).
  5. CONDENSATE DRAIN (1 x  $\phi$ 20mm PVC).
  6. ELECTRICAL ENTRY (2 x  $\phi$ 20mm).
  7. REFRIGERATION PIPING SUCTION 1 1/8", LIQUID 5/8".
  8. DUCTING OPTIONS - TOP S/A.

REV No	DATE	DETAILS
REV A	14.09.2011	NEW
REV B	14.02.2012	100mm WIDER & TOP S/A
REV C	03.05.2012	MODEL TITLE UPDATE
REV D	29.07.2013	NOTES & DIMS REVISED

DRAWING No.

CAG025007

REVISION	REV D
DATE	03.05.2012

HIA025R2AD, HIA025C2AD, HIA030R2AD, HIA030C2AD  
HIA035R2AD, HIA035C2AD, HIA038R2AD, HIA038C2AD

CUT SIZE	----	SCALE	1 : 20
MATERIAL	----	DRAWN	JA
QUANTITY	----	APPROVED	MD

- ALL DIMENSIONS IN mm.
- GENERAL TOLERANCE  $\pm$ 1mm.
- DO NOT SCALE DRAWING.
- MASTER DRAWINGS ARE HELD ELECTRONICALLY. ANY COPY IS DEEMED UNCONTROLLED AND THEREFORE NOT NECESSARILY THE LATEST REVISION.
- ALL INFORMATION REMAINS THE PROPERTY OF THE COMPANY.

GENERAL ARRANGEMENT

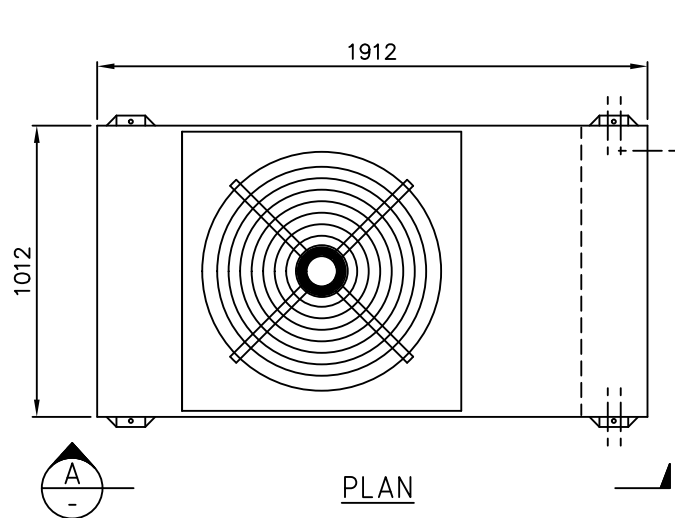

PLAN

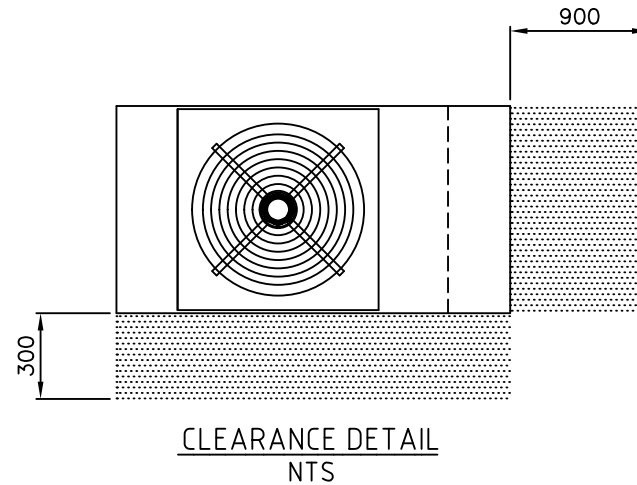

CLEARANCE DETAILS

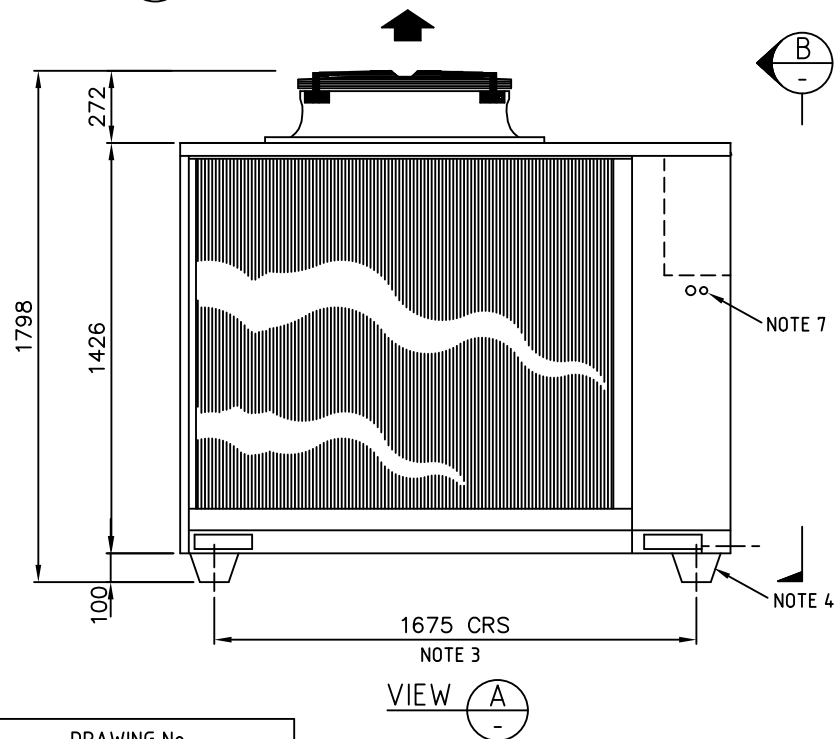

VIEW A

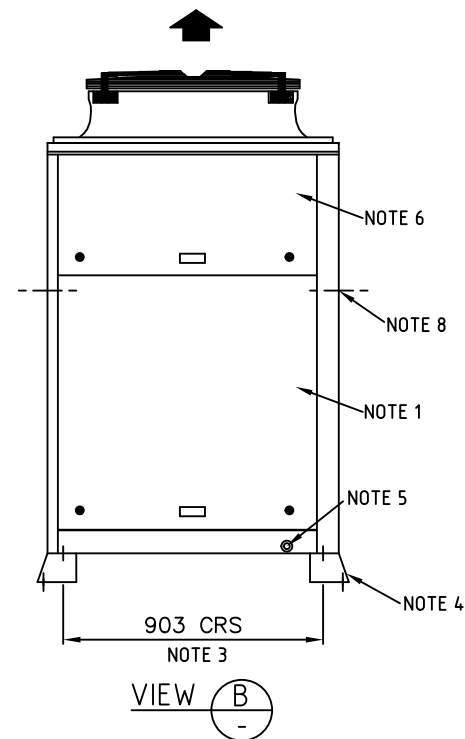

VIEW B

- NOTE:**
1. CABINET SERVICE ACCESS.
  2. TRANSPORTATION FEET (REMOVAL IS OPTIONAL).
  3. AV MOUNTING LOCATIONS (FEET MUST BE REMOVED).
  4. RECOMMENDED LIFTING POINTS SLING THROUGH TRANSPORTATION FEET, SEE NOTE 2. SPREADER BARS MUST BE USED.
  5. CONDENSATE DRAIN (1 x  $\phi$ 20mm PVC).
  6. ELECTRICAL SWITCHBOARD.
  7. ELECTRICAL ENTRY (1 x  $\phi$ 25mm & 1 x  $\phi$ 32mm)
  8. REFRIGERATION PIPING SUCTION 1 1/8", LIQUID 5/8"

REV No	DATE	DETAILS
REV 1	13.04.2012	NOTES UPDATED
REV 2	10.05.2012	UNIT HEIGHT WAS 1310 CHANGED TO 1365
REV 3	07.11.2012	TITLE BLOCK UPDATED
REV 4	05.07.2013	NOTES UPDATED
REV 5	30.07.2013	NOTES & DIMENSIONS REVISED
REV 6	24.04.2014	UPDATED AV MOUNT CENTRES

DRAWING No.

CAG025003

REVISION	REV 5
DATE	05.07.2013
SCALE	1 : 25
DRAWN	SP
APPROVED	MD



HOA025R3AB, HOA025C3AB HOA030R3AB, HOA030C3AB  
 HOA035R3AB, HOA035C3AB HOC025R3AB, HOC025C3AB  
 HOC030R3AB, HOC030C3AB HOC035R3AB, HOC035C3AB  
 HOC038R3AB, HOC038C3AB

GENERAL ARRANGEMENT

- ALL DIMENSIONS IN mm.
- GENERAL TOLERANCE  $\pm$ 1mm.
- DO NOT SCALE DRAWING.
- MASTER DRAWINGS ARE HELD ELECTRONICALLY. ANY COPY IS DEEMED UNCONTROLLED AND THEREFORE NOT NECESSARILY THE LATEST REVISION.
- ALL INFORMATION REMAINS THE PROPERTY OF THE COMPANY.